

# Tracking the sodium layer altitude with GeMS in the era of NGS2

Eduardo Marin<sup>\*a</sup>, Gaetano Sivo<sup>a</sup>, Vincent Garrel<sup>b</sup>, Pedro Gigoux<sup>a</sup>, Cristian Moreno<sup>a</sup>, Marcos van Dam<sup>c</sup>, Brian Chinn<sup>a</sup>, Paul Hisrt<sup>d</sup>, Vanessa Montes<sup>a</sup>, Rene Rutten<sup>a</sup>

<sup>a</sup>Gemini Observatory, AURA casilla 603, Colina El Pino, La Serena, Chile; <sup>b</sup>Max Planck Institute for Extraterrestrial Physics, Gießenbachstraße, 85741 Garching bei München, Germany; <sup>c</sup>Flat Wavefronts, 21 Lascelles Street, Christchurch, New Zealand; <sup>d</sup>Gemini Observatory, 670 N. A'ohoku Place, Hilo, Hawaii, USA

## ABSTRACT

Laser Guide stars are produced by the excitation of the sodium layer in the Earth's Mesosphere approximately 90 KM above sea level. While these artificial sources can be used for wave front sensing the mean altitude of the sodium layer is needed in order to extract the correct focus. In the Gemini South Multi Conjugate Adaptive Optics System (GeMS), this is done by a Slow Focus Sensor (SFS) that looks at a Natural Guide Star to effectively track the mean sodium altitude. GeMS is set to enter a new era of science with an upgrade for its Natural Guide Star wave front sensor (NGS2). NGS2 is a complete replacement for the current Natural Guide Star wave front sensor (NGS). This presents an interesting challenge as the current NGS contains the SFS. With the NGS2 setup, this SFS will be removed and a suitable replacement must be found. Peripheral Wave Front Sensor one (PWFS1) a facility guider has been selected as the replacement. We will present the results of nighttime test to cross correlate the focus data obtained by the current SFS and PWFS1.

**Keywords:** AO, LGS, MCAO

## 1. INTRODUCTION

### 1.1 Laser guide stars

Modern large telescopes use Adaptive Optics (AO) to correct for the image degradation caused by the Earth's atmosphere. These systems use a fast wave front sensor and a fast deformable mirror. In order to properly measure the atmospheric turbulence, the WFS needs to sample to at several hundred hertz and on more advanced systems into the kilohertz domain. The amount of bright natural guide star sources in the sky is limited, greatly reducing the area of the sky in which AO observations can be performed. The creation of an artificial guide star with a laser (Foy & Labeyrie 1985)<sup>[1]</sup> provides a solution to this problem. Such an artificial guide star can be created from the resonate backscattering of mesospheric sodium atoms. The Gemini observatory uses a constellation of five laser guide stars to feed its Multi-Conjugate Adaptive Optics (MCAO) system GeMS.

### 1.2 Sodium layer variations

While an artificial guide star can be formed in the sodium layer, this source is not perfect. One of the issues being that while sodium (Na) atoms in the mesosphere form a layer at an average altitude of 90-95km above sea level, this altitude can vary from 85km to 105km. The mean altitude of the sodium layer varies quickly enough that throughout an AO observation an AO system must be able to distinguish atmosphere-induced focus from the slow focus drift caused by variation in the guide star altitude (Neichel et al. 2013)<sup>[2]</sup>. GeMS currently has a Slow Focus Sensor (SFS) to monitor the change in the sodium altitude. The SFS does this by looking at a natural guide star and calculating the residual focus. If the natural guide star is not in focus on the SFS this means that the Laser Guide Star wave front sensor (LGSWFS) is not looking at the correct sodium altitude. This SFS is being replaced along with the entire Natural Guide Star wave front sensor (NGSWFS) assembly in an upcoming upgrade to GeMS known as NGS2.

\*emarin@gemini.edu; phone 56 51 2205-648

## 2. HOW DO WE CURRENTLY MEASURE FOCUS

### 2.1 GeMS Overview

GeMS, is the Gemini Multiconjugate adaptive optics system. It uses a 1' diameter constellation of 5 laser guide stars, produced from a single 50W laser, and 3 natural guide stars for tip-tilt correction. Typical strehls are 20% in K band in a 85"x85" FoV. For a full review of GeMS design and commissioning see Rigaut et al. (2014)<sup>[3]</sup> and Neichel et al. (2014)<sup>[4]</sup>. For details about the Gemini South Adaptive Optics Images (GSAOI) see McGregor et al. (2004)<sup>[5]</sup> and Carrasco et al. (2012)<sup>[6]</sup>.

### 2.2 The current system

GeMS currently has a Slow Focus Sensor (SFS) that is part of the current NGSWFS. Light coming into the adaptive optics bench Canopus is split by a dichroic beam splitter. This sends IR light to the science cameras and sends visible light to the wave front sensors. A second beam splitter then sends 589nm laser light to the LGSWFS and the remaining optical light passes to the NGSWFS. The light that passes into the the NGSWFS is then again split with 30% of the light of one of the 3 nature guide stars going to the SFS. The SFS being a 2x2 Shack-Hartman wave front sensor. The SFS will calculate the amount of focus and send an adjustment to the zoom lenses of the LGSWFS, this will then put a focus term on DM0 which will be offloaded to the Gemini secondary mirror. This loop continues with updates to the focus value on relatively slow time scales of seconds.

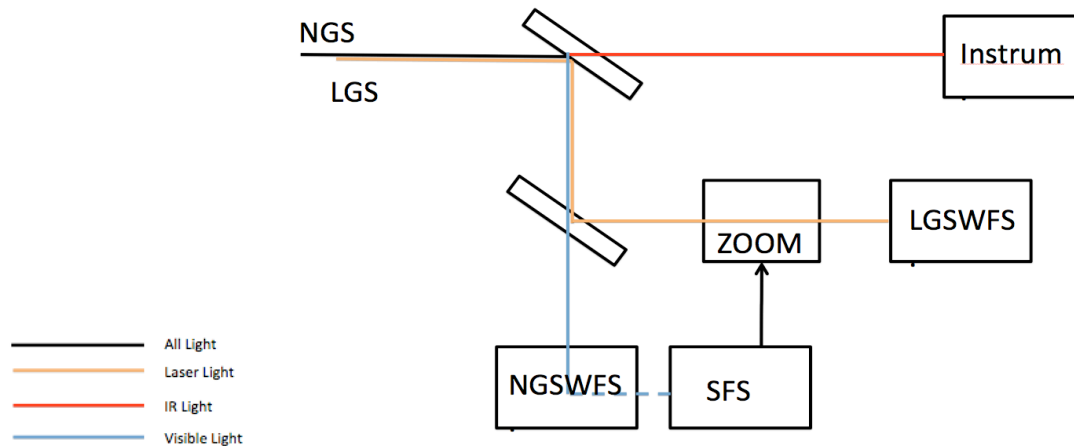

Figure 1: Current system layout

## 3. THE NEW WAY

### 3.1 NGS2

Gemini south is in the process of upgrading the GeMS system. One of these upgrades is replacing completely the NGSWFS. The reason for this upgrade is that with the current NGSWFS the limiting magnitude of stars that can be used is only ~15.5 R-Mag, this provides poor sky coverage away from the galactic center. The goal with the new WFS is to get to ~17+ R-Mag. This will open up whole new areas of the sky to GeMS and lead to new science opportunities. See figure 2 for a comparison of the sky coverage.

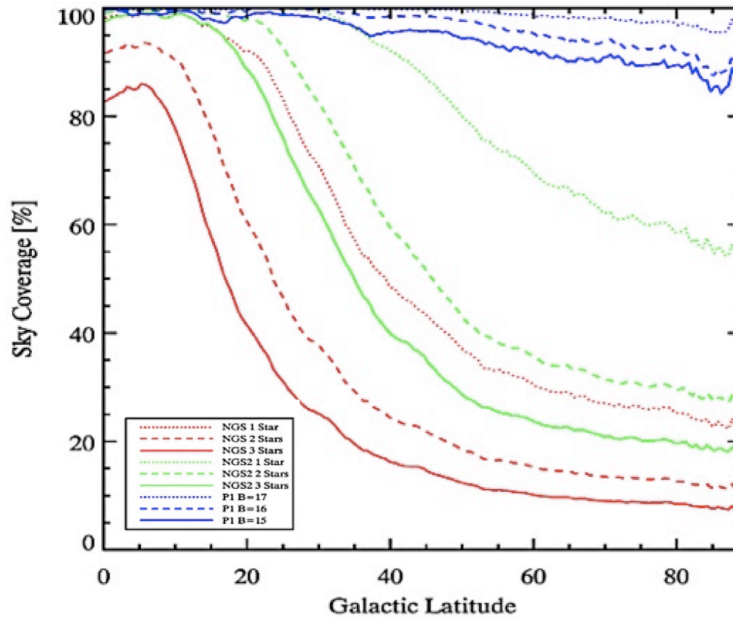

Figure 2 Sky coverage with NGS2 vs current NGS

In addition to the greater sky coverage the desire is also to get a system that is more efficient. The current NGSWFS is based on 3 guide probes that feed 3 2x2 APD wave front sensors. These wave front sensors are on probe arms that patrol the Canopus 2'x2' FoV and each has a FoV of 1.7". This makes it sometimes difficult to find the natural guide stars as the FoV of the field is large compared to that of the WFS. The new system known as the Next Generation natural guide star wave front sensor for GeMS (NGS2) is based on a single fast readout EMCCS camera, providing a full view of the 2'x2' field of view see Rigaut 2016<sup>[7]</sup> for a full description of NGS2. NGS2 is a complete replacement on the current natural guide star wave front sensor, meaning that the current SFS will be removed and a replacement will have to be found. The facility guider Peripheral Wave Front Sensor One (PWFS1) was decided to be used. See Marin et al. (2015)<sup>[8]</sup> for an explanation of why PWFS1 was selected as the replacement for the current SFS and the testing done to ensure that it would be able to function as such.

### 3.2 Focus differences

The ways that the current SFS and PWFS1 calculate focus are different. The current SFS looks at the focus from a natural guide star and moves the LGSWS zoom lenses until the natural guide star is in focus, while PWFS1 looks at the focus from a natural guide star and moves the focus of the Gemini secondary mirror directly until the natural guide star is in focus. The other important note is that PWFS1 is located outside of the adaptive optics bench and is before the adaptive optics fold mirror. This means that PWFS1 will need to be used off-axis so as to not vignette the entrance to the adaptive optics bench. To compensate for the variation between on-axis and off-axis focus PWFS1 has an internal focus stage that can move +/- 15 mm.

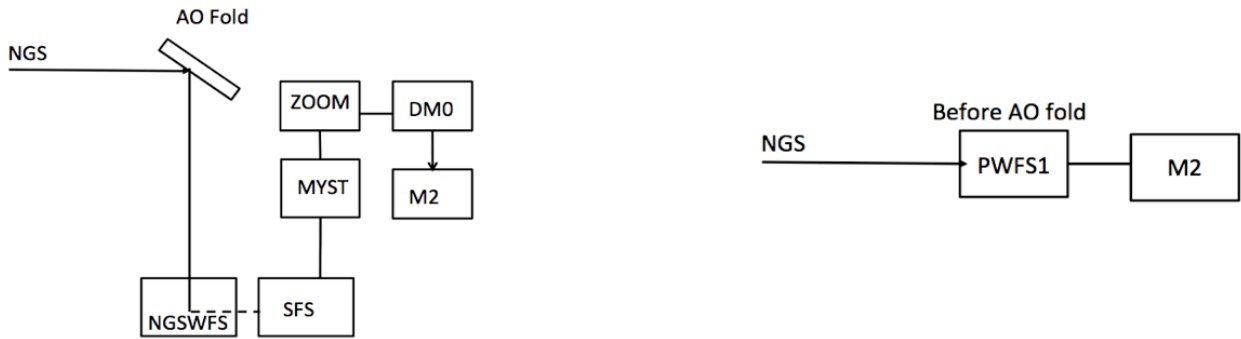

Figure 3: Left: Current SFS, Right: current PWFS1

As seen in Figure 3 the current SFS sends its data to MYST which is the high level MCAO software and then adjusts the zooms. While PWFS1 does its own focus calculation. In both cases the end result is that the Gemini secondary mirror (M2) is moved to have the natural guide star in focus on the respective wave front sensor.

### 3.3 How to use PWFS1 as the new SFS

While PWFS1 can and does move the focus of M2 directly already this is not what we want for GeMS in NGS2. We want the same as the current SFS in that we want to adjust the LGSWFS zoom to adjust the focus, because moving the zooms is essentially making the adjustment for the change in the mean sodium altitude. While the end result is that the focus on M2 is changed, if we were to change directly the focus on M2 without adjusting the zoom lenses to the proper sodium altitude we would introduce a focus term to DM0 that would attempt to undo the change we had just done with PWFS1. In order to send the correction to the LGSWFS zooms and not directly to M2 we have two options. Either we follow the same path as the current SFS and we send directly the raw data to MYST which will then calculate a focus offset and move the zooms or we can use the focus calculation from PWFS1 and use that value to move the zooms.

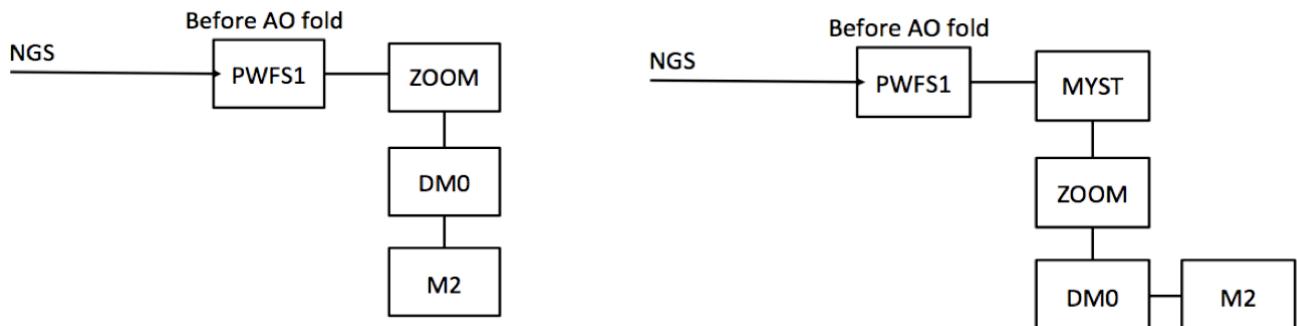

Figure 4 Options to use PWFS1 as SFS. Left: PWFS1 runs zoom directly, Right: PWFS1 sends images to MYST

Both of the above options work, but one is much more straightforward to implement. As PWFS1 is a 6x6 Shack-Hartman and the SFS is only a 2x2, we would prefer not to have to modify the MYST code to calculate the focus from PWFS1 and use the focus that is already calculated by the PWFS1 software. This means that we want PWFS1 to drive the LGSWFS zoom lenses directly. As a consequence we have to take the value that is produced by PWFS1 which is in millimeters of M2 focus and correlate it with the values that the LGSWFS zoom lenses will accept which are kilometers of sodium altitude change. A campaign was started to cross-correlate the current SFS with PWFS1

## 4. CROSS-CORRELATION OF FOCUS VALUES

### 4.1 PWFS1 vs SFS

During several nights in which we were using the GeMS AO system we ran both PWFS1 and the current SFS to calculate focus. We left the SFS in closed loop sending corrections to the LGSWFS zoom lenses, while PWFS1 was left off-axis in open loop calculating its own focus values. This was repeated throughout the night in order to get a good understanding of the correlation of the two values. As the SFS only sees 30% of the light from one the 3 NGS source while PWFS1 is directly looking at an off-axis star the integration times of each system were different. The data from both PWFS1 and the SFS were synchronized so that we could compare what each was measuring. Figure 5 shows the data over once night. The data show a strong correlation between the two values after a liner fit is done to the data.

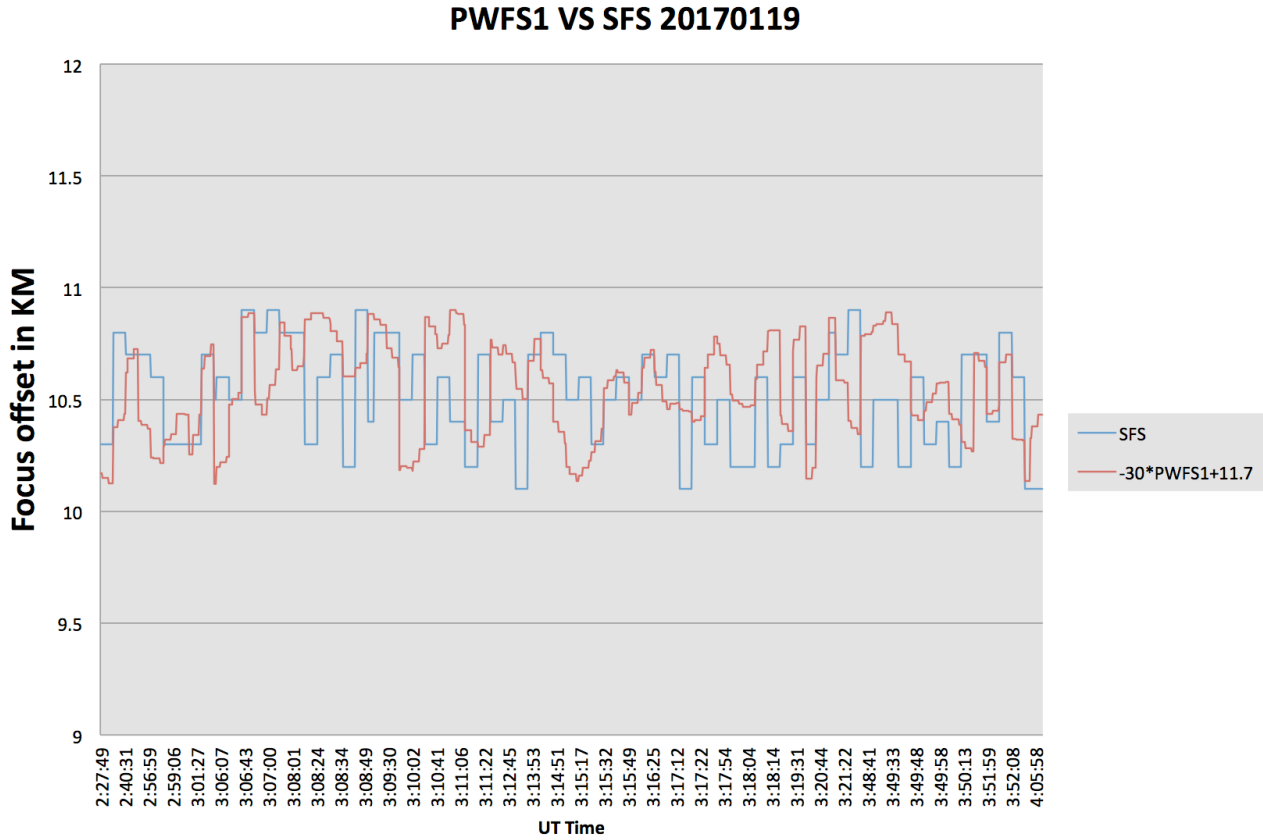

Figure 5 SFS focus vs PWFS1 focus (data have been sigma clipped)

After this data were collected and sigma clipped to produce a linear relationship between the two values. Equation 1 below is the relationship that was found.

$$\text{SFS}_{\text{focus}} = (-30 * \text{PWFS1}_{\text{focus}}) + 11.7 \quad (1)$$

This produced an RMS error of 0.287 km. From experience using the GeMS system we see that the performance on GSAOI starts to degrade when we have a 0.5 km error in the focus, so having an RMS of almost half of that is within our

performance budget. We do not expect to see a measureable change in performance if the correlation maintains itself at this level.

## 5. MOVING FORWARD

### 5.1 Additional test

While the data above give a good first estimate of the correlation between the two focus values it is preliminary. The use of the GeMS system at Gemini south is limited to 2-3 runs per semester of 5-7 nights each. This is mostly due to the lack of reliability of the laser system. As a consequence, we have limited opportunities to take measurements for this cross-correlation. The NGS2 system is progressing and we expect it to be delivered mid 2018, therefore the test and the implementation of PWFS1 must be done before then. We plan to have the LGSWFS zooms being controlled directly by PWFS1 before the installation of NGS2, so that we can compare with the current SFS. In addition to the NGS2 upgrade Gemini South is also in the process of installing a new much more reliable laser system. With this new laser, it is expected that we will be able to have more laser runs in a semester and thus more time for testing. Upcoming laser runs in the latter half of 2017 and at the start of 2018 will be the time for us to continue this work in preparation of the new system being installed and operational. If the test show that it is unreliable to use the direct PWFS1 measurement then we would have to send the raw data to MYST as outlined above and do the calculation there much the same as it is currently.

## 6. CONCLUSIONS

The new NGSWFS for GeMS NGS2 while increasing the science potential of GeMS this upgrade also poses an interesting challenge to the tracking of the sodium layer. With the removal of the current system a new way of tracking the sodium has been proposed. This new way is to use the facility WFS that is optically in front of the Adaptive Optics bench. PWFS1 being a facility guider already calculates its own focus value from an NGS source, it has its own software package that will then use this value to directly move the Gemini secondary mirror to compensate for focus. This value is the ideal one to use to run the LGSWFS zoom lenses, but it must first be correlated to the values that are being produced by the current SFS. From the early results, it looks like the least invasive approach is to use the values that are calculated by PWFS1 to move directly the LGSWFS zoom lenses. A linear relationship has been found to relate the two quantities and this relationship produced an error that is within the current error budget.

There however remains the risk that such an approach will not work in the end. The values calculated by PWFS1 are in mm of M2 and not a direct tracking of the mean sodium altitude. It may be necessary to feed the raw information to MYST and have it do the focus calculation as is currently done with the SFS. While this is not the most ideal situation as it adds one more layer of complexity, it may be the most accurate. The further testing, we have proposed for the time between now and the installation of NGS2 should give us ample time to find out which of the two approaches is the most accurate and which will be implemented in the end.

## ACKNOWLEDGEMENTS

The Gemini Observatory is operated by the Association of Universities for Research in Astronomy, Inc., under a cooperative agreement with the NSF on behalf of the Gemini partnership: the National Science Foundation (United States), the National Research Council (Canada), CONICYT (Chile), Ministério da Ciência, Tecnologia e Inovação (Brazil), and Ministerio de Ciencia, Tecnología e Innovación Productiva (Argentina).

## REFERENCES

- [1] Foy, R. and Labeyrie, A. "Feasibility of adaptive optics telescope with laser probe," *A&A*, 152, L29-L31 (1985)
- [2] Neichel, B. et al., "Characterization of the sodium layer at Cerro Pachón, and impact on laser guide star performance," *MNRAS*, 429, 3522 (2013)
- [3] Rigaut, F. et al., "Gemini multiconjugate adaptive optics system review – I. Design, trade-offs and integration," *MNRAS*, 437, 2361 (2014)
- [4] Neichel, B. et al., "Gemini multiconjugate adaptive optics system review – II. Commissioning, operation and overall performance," *MNRAS*, 440, 1002 (2014)

- [5] McGregor, P., Hart, J., Stevanovic, D. and et al., "Gemini South Adaptive Optic Imager (GSAOI)," Proc. SPIE 5492 1033-1044 (2004)
- [6] Carrasco, E. R. et al. "Results from the commissioning of the Gemini South Adaptive Optics Imager (GSAOI) at Gemini South Observatory", Proc. SPIE 8447, Adaptive Optics Systems III, 84470N, (2012)
- [7] Rigaut F. et al., "NGS2: a focal plane array upgrade for the GeMS multiple tip-tilt wavefront sensor," Proc SPIE 9909 id. 99091X 16 pp. (2016)
- [8] Marin, E. et al., "A New Slow Focus Sensor for GeMS". *Adaptive Optics for Extremely Large Telescopes 4 – Conference Proceedings*, 1(1). doi: 10.20353/K3T4CP1131578. ao4elt4\_31578. (2015). Retrieved from: <http://escholarship.org/uc/item/10b151nz>